

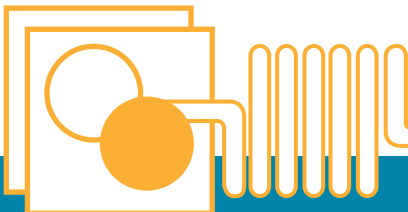

Orkot[®] COMPOSITE BEARINGS

SERVING THE WORLDS ENGINEERING AND MARINE MARKETS



ORKOT manufacture a range of thermoset composite bearing materials incorporating advanced polymer technologies. These are made from technical fabrics impregnated with thermosetting resins, evenly dispersed solid lubricants and further additives to ensure the optimum solution is reached to satisfy many engineering applications.

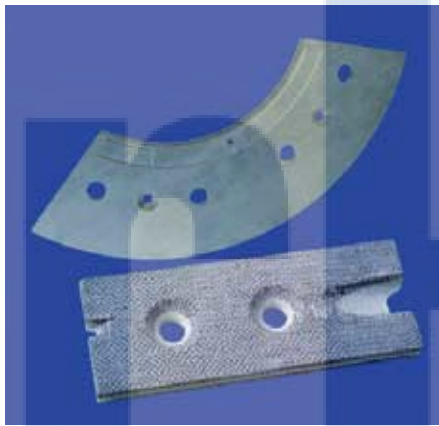

Due to their good mechanical and physical properties ORKOT materials are outstandingly suited for use as guides and bearings subject to high loads. As guide rings in hydraulic applications, guides on slide ways for reciprocating pistons, rods, plungers, slide and guide rails and as bearings, thrust washers and bearing shells for rotating and oscillating drums, shafts, bushings, and spindles.

The wear of ORKOT materials can be less than that of conventional metallic bearing materials. Therefore, depending on the application, longer service life can be achieved with a simultaneous improvement in the properties of the component.



ORKOT composite materials are applicable for a wide range of markets to include

- Railways
- Off-Road Vehicles
- Process Equipment
- Injection Moulding Machines
- Pumps and Valves
- Lifting and Handling Equipment
- Paper Machines
- Steel Mills
- Water Filtration Plants
- Hydraulic Cylinders
- Food Industry (FDA Approved)

TYPICAL APPLICATIONS

Many successful applications for ORKOT involve highly loaded bearings or pads operating with intermittent or oscillating movements. ORKOT bearings are successfully used against many different counter face materials including hardened steel, stainless steel, gun metal, chrome plated steel, ceramic coated steel, and nitrided surfaces. In steel mills ORKOT C321 (TL Grade) is a suitable replacement for metallic bearings on cylinder rod ends as the outer ring due to its resistant to vibrations, dirt and hot water. ORKOT materials do not build up static charge and are suitable for applications in which interference with magnetic or electric fields must be prevented. ORKOT materials are resistant to many chemicals. They do not corrode and are unaffected by many solvents, inorganic solutions and weak acids. Water based chemicals can also act as lubricants.

KEY FEATURES

- Low Coefficient of Friction
- High Load Capacity
- Good Chemical Resistance
- Fitting by Pressing, Freezing, Adhesives, and Mechanical Methods
- Operates in Fresh and Salt Water without Lubrication
- Damping of Vibration
- Ease of Machining
- Accommodation of Shaft Misalignment
- Reduced Thermal Softening and Minimal Creep
- Dimensional Stability
- Does not Encourage Galvanic Corrosion
- Swell in Water of many grades <0.1%
- Contains no Asbestos or Environmentally Hazardous/Toxic Substances

APPLICATIONS

- Rudder Bearings
- Stern Shaft Bearings
- Staves
- Linkage Bearings
- Main Shaft Bearings
- Shaft Seals and Bearings
- Radial Bearings
- Hinge Bearings
- Seal Rings
- Wear Pads
- Thrust Washers and Bearings
- Stabiliser Bearings
- Deck Machinery Bearings
- Sonar Bushing and Guide Strips
- Crane Mast Bearings
- Door Bushes
- Steering Gear Bearings
- Slipway Pads
- Bushes
- Wear Rings
- Spherical Bearings Assemblies
- Guide Ring for Pistons or Rod
- Cylinder Rod and Bearing
- Slide Pads

ORKOT MARINE BEARINGS

ORKOT C322 (TLM) MARINE incorporates solid lubricants which enable dry running to ensure outstanding wear life. The material will operate without lubrication at pressures of 30 N/mm² for short periods and has been tested at pressures of 14.5 N/mm² with a velocity of 1.3m/min for 1.5 million cycles with minimum lubrication. ORKOT C322 (TLM) Marine is also suitable for the majority of water lubricated stern shaft systems.

ORKOT TXM MARINE is a high performance material which exhibits lower friction and wear properties than the TLM Marine grade. It is approved to operate without lubrication in rudder bearing applications and has been tested, with lubrication against stainless steel for submarine steering gear at 57 N/mm² at 1m/min. In other areas without lubrication the ORKOT TXM Marine material has been especially effective in eliminating stick slip problems associated with dry running conditions giving the materials a broad range of hydro applications. ORKOT TXM Marine is especially suitable for low shaft velocities as used in submarine or naval surface ship stern shafts.

It should be noted that ORKOT materials are not suitable for use in high speed grease or oil lubricated stern shaft systems.



MACHINING

ORKOT materials are readily machinable by conventional machine shop techniques. As a general guide methods used for brass, aluminium or lignum vitae apply for ORKOT materials. It is preferable to use tungsten carbide cutting tools with cutting speeds of 5.5 metres per second. ORKOT materials must be machined dry without the use of coolant. ORKOT materials are easily drilled using either conventional high speed steel or carbide tipped drills.

MATERIAL PROPERTIES	UNITS	ORKOT C322 (TLM MARINE)	TXM MARINE
GENERAL		Exceptional wear resistance, Low swell rate, low friction	Excellent mechanical strength Exceptional wear resistance Virtually no swell in water Superior dimensional stability
Compressive Strength			
Normal to Laminate	N/mm ²	346	>280
Parallel to Laminate	N/mm ²	92	>90
Tensile Strength	N/mm ²	60	>55
Flexural Strength	N/mm ²	>65	>65
Elastic Modulus			
Bending	N/mm ² x 10 ⁴	0.19	0.18
Tensile	N/mm ² x 10 ⁴	0.32	0.32
Shear Strength	N/mm ²	80	80
Impact Strength Charpy Unnotched			
Normal to Laminate	KJ/m ²	122	122
Hardness Rockwell M		100	100
Density	g/cm ³	1.3	1.3
Water Absorption	%	<0.1	<0.1
Coefficient of Linear Expansion			
Temperature Range +20 °C to +100 °C	10 ⁻⁵ /°C		
Perpendicular to Laminate		9-10	9-10
Parallel to Laminate		5-6	5-6
Max. Operating Temperature	°C	130	130
Min. Operating Temperature	°C	-40	-40
Operating Temperature			
Range for Normal use	°C	-30/65	-30/65
Sliding Properties*		0.13	0.05-0.10

* Typical coefficient of friction running dry against a corrosion resistant surface such as a stainless steel. Bearing pressure 15 N/mm²

MATERIAL PROPERTIES	UNITS	C321 (TL GRADE)	C320 (TLG GRADE)
GENERAL		High compressive strength, low swell rate, resistant to gamma radiation	High Wear Resistance High permissible surface pressure, vibration damping
Compressive Strength			
Normal to Laminate	N/mm ²	345	345
Parallel to Laminate	N/mm ²	95	92
Tensile Strength	N/mm ²	55	65
Modulus of Elasticity Tension	N/mm ²	3200	3200
Density	g/cm ³	1.25	1.30
Water Absorption	%	<0.1	<0.1
Hardness Rockwell M		100	100
Coefficient of Linear Expansion			
Temperature Range +20 °C to +100 °C	10 ⁻⁵ /°C		
Perpendicular to Laminate		9-10	9-10
Parallel to Laminate		5-6	5-6
Max. Operating Temperature	°C	+130	+130
Max. Application Temperature in Water	°C	+100	+100
Min. Operating Temperature	°C	-40	-40
Thermal Conductivity	W/m ^{°K}	0.293	0.293
Insulation Resistance	MOhm	2000	-
Dielectric Strength at 90°C			
Perpendicular to Fabric	V/mm	210	-
Dielectric Constant up to 1MHz (permittivity)		3.1	-



DEFORMATION AND ELASTICITY

ORKOT materials exhibit elastic deformation under compressive loads. The plastic or permanent deformation can be ignored as long as the permissible load of 120 N/mm² is not exceeded. Under the technically permissible load, elastic deformation is approximately 10% of the material thickness. These figures are valid for compressive loads perpendicular to the direction of lamination. It should also be noted that the permissible load and deformation are heavily dependent on temperature. Recommendations for the correct load direction as a function of the different types of load are shown in Figure 1.

AVAILABILITY

ORKOT is available as fully machined components or can be supplied as raw material in sheet, rod, or tube form. Components supplied from flat laminate are available in lengths up to 3000mm. Tube and rod is available in sizes from 10mm to 2000mm.

ORKOT TXMM bearing material is available in tube and sheet form or it can be supplied fully machined to the customers drawing. The material can be supplied in sizes from 25mm to 1680mm diameter and in sheet sizes of 609mm x 1219mm and 406mm x 2997mm and in any thickness up to an including 100mm.

		RECOMMENDED	NOT RECOMMENDED
TYPES OF LOAD	COMPRESSIVE		
	TENSILE		
	FLEXURAL		
	SHEARING		

Figure 1: Types of load as a function of the fabric layers



Find DOTMAR at: www.dotmar.com.au

Victoria	30 - 32 Garden Boulevard, Dingley VIC 3172	Telephone +61 (03) 9552 4444	Facsimile +61 (03) 9552 4400	Email: dotvic@dotmar.com.au
New South Wales	2/5 Talavera Road, North Ryde NSW 2113	Telephone +61 (02) 9878 5544	Facsimile +61 (02) 9878 6366	Email: dotnsw@dotmar.com.au
Queensland	Bldg.1, Unit 3/29 Lysaght St., Acacia Ridge QLD 4110	Telephone +61 (07) 3423 8997	Facsimile +61 (07) 3423 8994	Email: dotqld@dotmar.com.au
South Australia	Unit 1, 487 South Road, Regency Park SA 5010	Telephone +61 (08) 8346 0011	Facsimile +61 (08) 8346 0022	Email: dotsa@dotmar.com.au
Western Australia	16 Bell Street, Canning Vale WA 6155	Telephone +61 (08) 9456 4700	Facsimile +61 (08) 9456 4711	Email: dotwa@dotmar.com.au

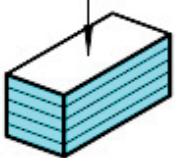
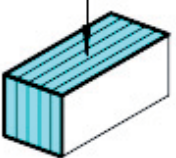
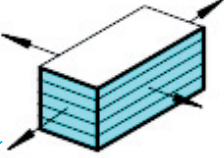
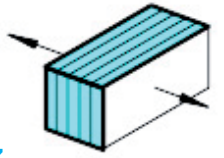
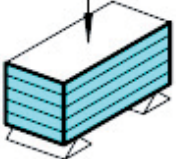
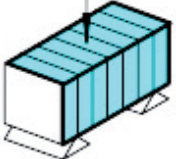
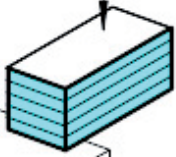
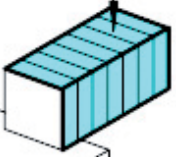
DEP-11/07

DOTMAR ...your partner in performance plastics.