

NUVEX®



INNOVATION IN ARCHITECTURAL DESIGN & CONSTRUCTION



NUVEX®

designed for **cost**
efficiency low maintenance
and **durability**...



contents

Sanitary Partitioning 8

- Toilet Partitions
- Privacy Screens
- Shower Stalls

Cabinetry 11

- Vanities
- Counters
- Lockers
- Seating/Benches

Outdoor Recreational Areas 13

- Playgrounds
- Pool Grating
- Seating

Testimonials 15



NUVEX®

Innovation in *Architectural*
Design &
Construction...

- NUVEX Saniboard
- NUVEX Playboard
- NUVEX Leisureboard

WHO IS DOTMAR



Dotmar EPP was established in 1967, and is a privately owned, manufacturer, importer and distributor of semi-finished engineering thermoplastics and components throughout Australasia.

Dotmar has an innovative approach to the market and prides itself on leading edge thermoplastic product innovation and applications development.

Dotmar's focus is the technical application of thermoplastic materials in a number of exciting industries, ranging from pharmaceutical and materials handling to as far a field as architectural design.

Dotmar excels in distribution, technical support, material selection and applications development.

So why choose the market leader...

- Widest range of quality engineering thermoplastics
- Specialists in our field, offering the highest levels of material selection advice and technical support in the industry
- Largest distribution footprint
 - six state branches in Australia and five in New Zealand
 - large distributor network servicing remote locations
- Capital investment in inventory & technical machining centres- commitment to continuous material supply and customer service delivery
- Long-standing partnerships with the world leaders in thermoplastics manufacturing

environmentally friendly
timber replacement
materials...



WHY NUVEX

The demand for better ecologic and economic solutions in the construction industry without abandoning performance, makes high quality thermoplastic sheet a NEW no. 1 material, setting performance and life-cycle standards on top of the list.

DOTMAR's solid thermoplastic restroom partitions outperform phenol, timber, laminates and metal products in almost every measure of durability and economy. Resistant to mildew and odour, our plastic material will not rust, break or delaminate. DOTMAR's graffiti resistant partitions virtually maintain themselves – and require no painting or post treatment.

These features, together with 100% recyclability, define NUVEX® as one of the most ecologic construction materials guaranteeing low cost of maintenance for applications, which indicate a low total cost of ownership and an economic advantage over commonly used material

This makes NUVEX® a most suitable replacement for TRADITIONAL TIMBER PANEL BOARDS.



Nuvex sanitary
partitions **would never**
look like this...



Saniboard / Leisureboard



red



burgundy

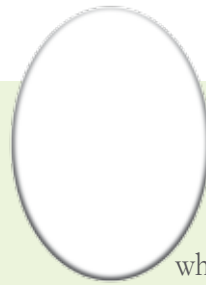

white



frost granite



hunter

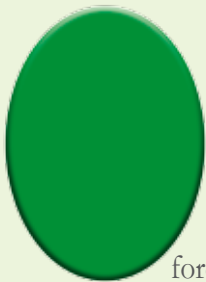

forest green

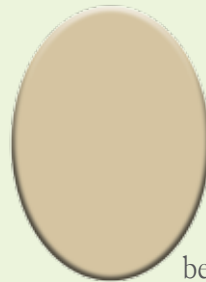

beige

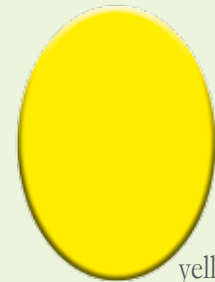

yellow



blueberry



blue

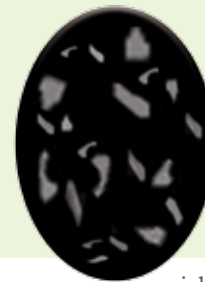

paisley

100% solid colour
and not laminated
product...

Sanitary Partitioning

Toilet Partitions



NUVEX Saniboard.

The most advanced and aesthetically pleasing material as an alternative to traditional timber panel construction material.

Dotmar's NUVEX thermoplastic is lightweight, easy to handle and the product itself is maintenance free.

All fittings can be tailored to suit customer requirements. Includes: Hinges, locks, door handles and hooks.

Benefits

- Will not break, swell, splinter or rust
- Will not delaminate or rot
- Solid colour throughout the material
- Strong, durable and impact resistant
- Chemically inert
- Graffiti resistant and easy to clean
- Resistant to mildew, mould and odours
- Environmentally sound
- 100% Recyclable

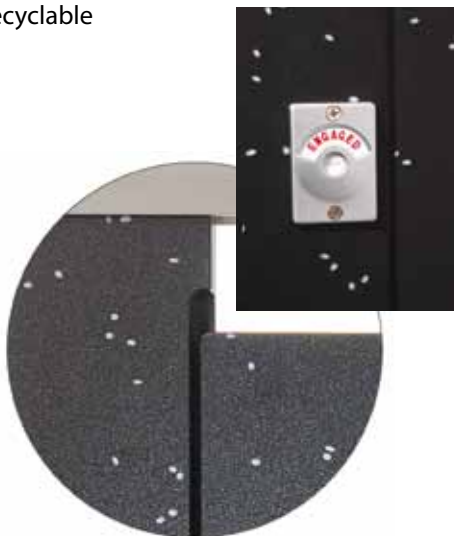

Long life cycle with **no deterioration** of material properties.

Pillar rebate eliminates gaps between the pillar and door ensuring **total privacy**.

Sanitary Partitioning

Toilet Partitions / Privacy Screens



Nuvex is **virtually unbreakable**
- fastening methods are not subjected to fatigue.

Easy to **install**.

FRONT ELEVATION
(Maximum Ceiling Height 3m)
Not To Scale

Style

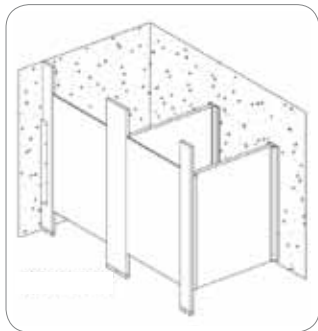

CEILING-HUNG

Ideal where floor maintenance is imperative. Requires structural elements at the pilaster to ceiling connection. Max height 3m

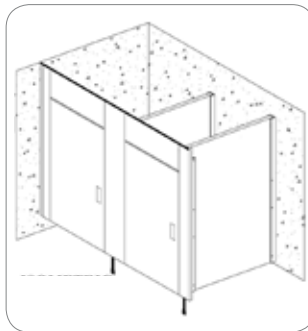

FLOOR-MOUNTED OVERHEAD-BRACED

Strongest and most economical installations



FLOOR-TO-CEILING MOUNTED

Ideal for situations where head rails are not desired. Requires structural elements at the pilaster to ceiling connection. Max height 3m

Sanitary Partitioning

Shower Stalls

Nuvex is **moisture resistant** and therefore ideal for shower partitions and other wet area applications.

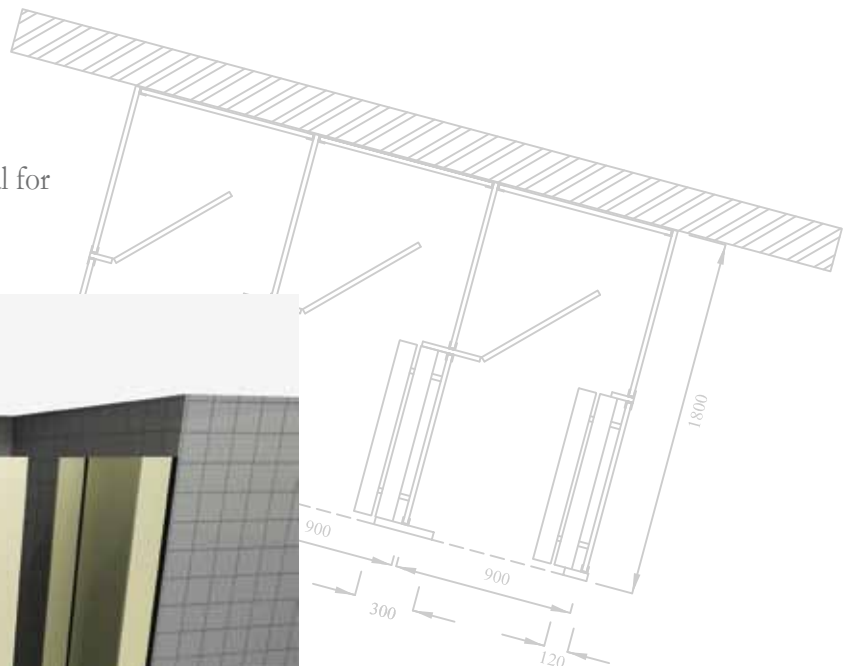

Fill Threshold Area of Base With
Caulk to Create a Water Stop
When Panels Are in Place.

Benefits

- Will not break, swell, splinter or rust
- Will not delaminate or rot
- Solid colour throughout the material
- Strong, durable and impact resistant
- Chemically inert
- Graffiti resistant and easy to clean
- Resistant to mildew, mould and odours
- Environmentally sound
- 100% Recyclable



Cabinetry

Vanities / Counters

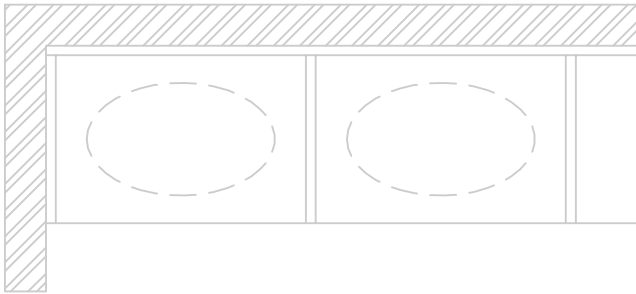

TOP VIEW

designed for **cost efficiency** low maintenance and **durability**...

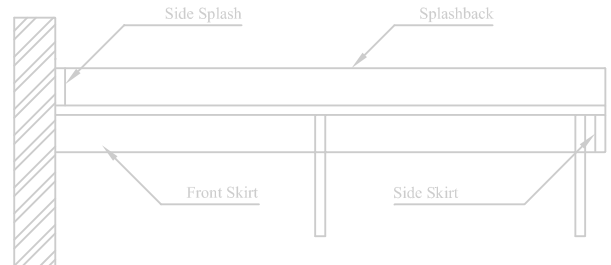

Up to **3m lengths** available.

Aesthetically **pleasing finish** with no joins or bending.

Cabinetry

Lockers / Benches



Nuvex is **virtually unbreakable** - fastening methods are not subjected to fatigue.

Provides **long term** strength with fitment of locking mechanisms for lockers.

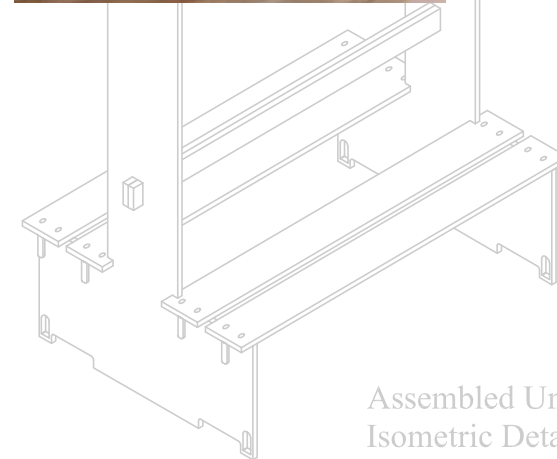

Benefits

- Will not break, swell, splinter or rust
- Will not delaminate or rot
- Solid colour throughout the material
- Strong, durable and impact resistant
- Chemically inert
- Graffiti resistant
- Non-stick surface that is easy to clean
- Resistant to mildew, mould and odours
- Environmentally sound
- 100% Recyclable

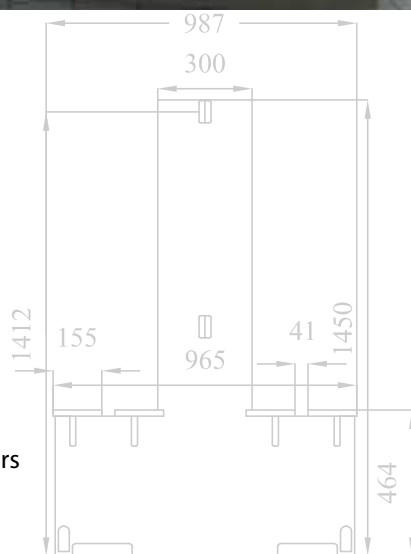

End Elevation

Outdoor Recreational Area

Playgrounds

Benefits

- Will not break, swell, splinter or rust
- Will not delaminate or rot
- Solid colour throughout the material
- OHS compliant
- Strong, durable and impact resistant
- Chemically inert and UV stable
- Moisture resistant
- Graffiti resistant
- Non-stick surface that is easy to clean
- Environmentally sound
- 100% Recyclable

Child **safe** material.



Outdoor Recreational Area

Pool Gratings

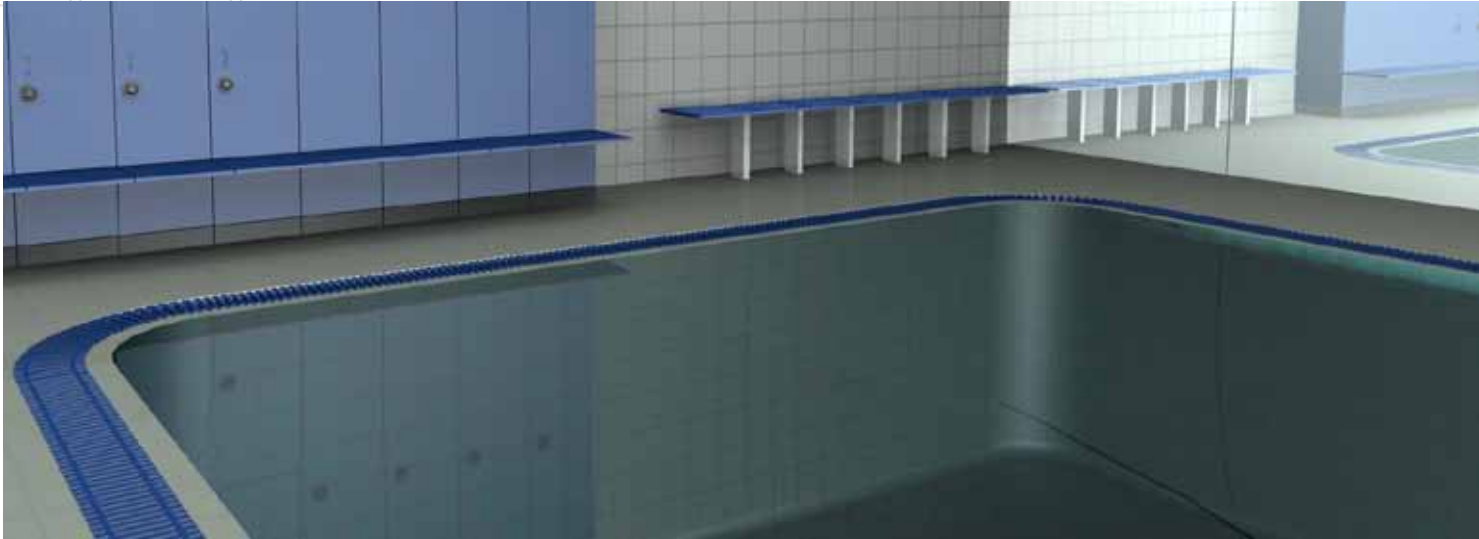

Nuvex is **extremely versatile** and can be fabricated to any shape with ease.

Can be **fabricated** to fit around curved areas.

To fit standard gutters with supports, Modules, 1200mm Long x 300mm Wide x 25 thick. Available in RED, BLUE & WHITE

designed for **cost efficiency** low maintenance and **durability**...

Testimonials



Project: Ian Thorpe Aquatic Centre - Ultimo NSW
Architect: Harry Seidler & Associates
Material: NUVEX® Leisureboard
Detail of Component: Module 1200 x 350 x 25mm pool grating
Key Features:

- No deterioration from Pool Chemicals
- Materials are UV Stabilised from the light

Advantages:

- Child Safe
- Will not Rot, Break or Splinter
- OHS Compliant
- Easy to Handle and Clean

Project: Cheltenham Secondary College - VIC
Material: NUVEX® Saniboard
Detail of Component: Toilet Partitions

Key Features:

- Resistant to Odour and Mildew
- Will not Rust, Break or Deteriorate
- Long Life Cycle

Advantages:

- Unbreakable
- Odourless
- Colour Fast / UV Stabilised
- Graffiti Resistant



Project: Peninsula Leisure Centre - Woy Woy, NSW
Architect: Michael Davies Associates
Material: NUVEX® Saniboard
Detail of Component:

Vanities and Impact resisting seating made to Architect's Specifications

Key Features:

- Resistant to Odour and Mildew
- Will not Rust, Break or Deteriorate
- Long Life Cycle

Advantages:

- Unbreakable
- Odourless
- Colour Fast / UV Stabilised
- Graffiti Resistant

Project: ABC Learning Centre
Material: NUVEX® Playboard
Detail of Component: CO Extrudant Tri-Colour Machined materials to specific detail

Key Features:

- UV Stabilised Colour Fast
- No Moisture Absorption

Advantages:

- Replacing Timber Panels with NUVEX®, removes OHS risk because of the indestructible qualities of the material
- Will not Splinter





AUSTRALIA

- Victoria
- New South Wales
- Queensland
- South Australia
- Western Australia
- Tasmania

NEW ZEALAND

- Auckland
- Christchurch
- Palmerston North
- Hamilton
- Dunedin

DOTMAR

ENGINEERED ARCHITECTURAL PLASTICS

www.dotmar.com.au • 1800 170 001 • sales@dotmar.com.au | www.dotmar.co.nz • 0800 650 750 • sales@dotmar.co.nz